

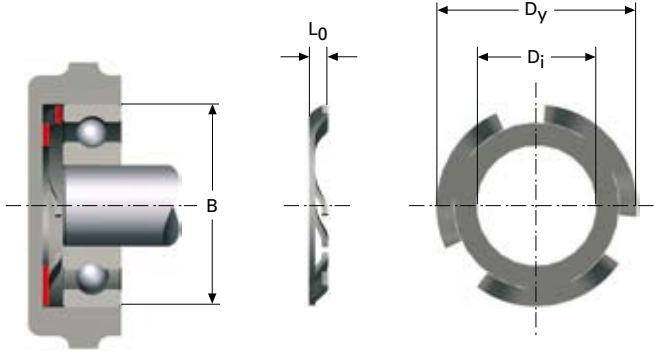

FINGER SPRING WASHERS

FB



Finger spring washers are used to dampen noise and vibration. They are particularly suitable for high speed applications and are also frequently used to eliminate play and axial wear. Washers with a D_y of 15.11 mm have three fingers, others have six.

All dimensions are in mm

D_y = Outer diameter

D_i = Inner diameter

L_0 = Unloaded length

L_1 = Loaded length

F_n = Spring force in Newtons at L_1

B = Outer diameter of bearing

Material: Spring steel CK 67

Finish: Untreated

1 kp = 9.80665 Newtons, 1 Newton = 0.10197 kp

D_y	D_i	L_0	L_1	F_1	B	Cat. no
15,11	7,92	2,38	1,57	1,4–4,4	16	7476
18,49	8,74	3,18	1,57	18–36	19	7477
21,49	8,74	3,18	1,57	13–31	22	7478
21,49	11,51	3,18	1,57	40–58	22	7479
23,52	11,51	3,18	1,57	27–45	24	7480
23,52	8,74	3,18	1,57	98–125	24	7481
25,5	13,11	3,18	1,57	22–40	26	7482
25,5	13,11	3,18	1,57	36–53	26	7483
29,57	10,31	3,18	1,57	67–93	30	7485
29,57	17,48	3,18	1,57	267–334	30	7486
29,57	17,48	3,18	1,57	45–62	32	7487
31,5	14,3	3,18	1,57	67–93	32	7488
31,5	17,48	3,18	1,57	67–93	32	7489
34,54	20,68	3,18	1,57	49–67	35	7490
34,54	20,68	3,18	1,57	76–111	35	7491
39,5	24,66	3,18	1,57	67–93	40	7492
39,5	25,4	3,18	1,57	138–174	40	7493
46,48	30,2	3,18	1,57	76–102	47	7494
51,35	34,52	3,18	1,57	76–102	52	7495