

# GASFJÄDER

TYP 15-6 EW

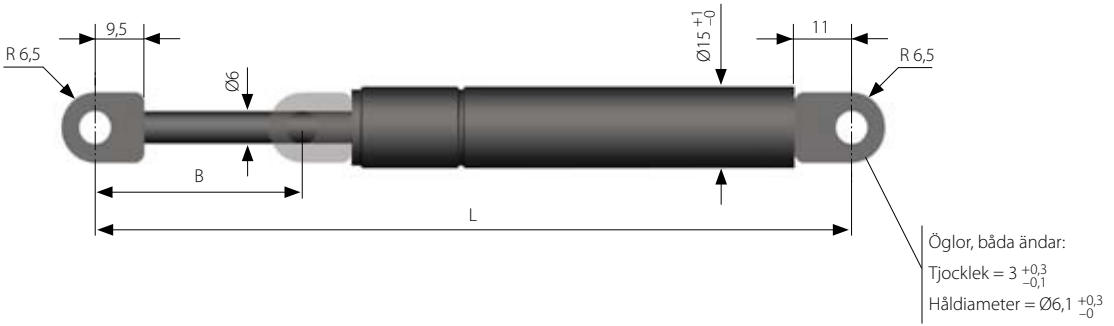

## Konventionell gasfjäder med svetsade öglor, utskjtningsfart ~0,3 m/s

Alla dimensioner i mm

L = Längd +/- 2

B = Slaglängd

F1 = Fjäderkraft i Newton

Kraftområde: 50-400 Newton

Ändfästen: Se sidorna 179-190.

1kp = 9,80665 Newton, 1 Newton = 0,10197 kp

L	B	F1	Art. nr
106	20	50	9058
106	20	100	9059
106	20	150	9060
106	20	200	9061
106	20	250	9062
106	20	300	9063
106	20	350	9064
106	20	400	9065
146	40	50	9066
146	40	100	9067
146	40	150	9068
146	40	200	9069
146	40	250	9070
146	40	300	9071
146	40	350	9072
146	40	400	9073
186	60	50	9074
186	60	100	9075
186	60	150	9076
186	60	200	9077
186	60	250	9078
186	60	300	9079
186	60	350	9080
186	60	400	9081
224	80	50	9082
224	80	100	9083
224	80	150	9084
224	80	200	9085
224	80	250	9086
224	80	300	9087
224	80	350	9088
224	80	400	9089

L	B	F1	Art. nr
264	100	50	9090
264	100	100	9091
264	100	150	9092
264	100	200	9093
264	100	250	9094
264	100	300	9095
264	100	350	9096
264	100	400	9097
305,5	120	50	9098
305,5	120	100	9099
305,5	120	150	9100
305,5	120	200	9101
305,5	120	250	9102
305,5	120	300	9103
305,5	120	350	9104
305,5	120	400	9105
366	150	50	9106
366	150	100	9107
366	150	150	9108
366	150	200	9109
366	150	250	9110
366	150	300	9111
366	150	350	9112
366	150	400	9113