

# GAS SPRINGS

Type 15-6 EF

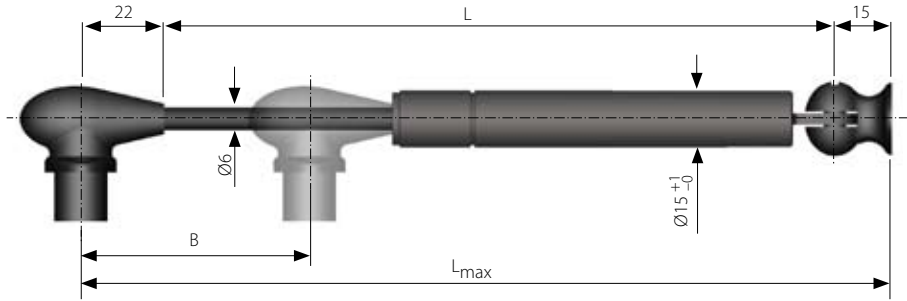

## Conventional gas spring for furniture applications

Ideal for overhanging doors. Available in two variants, which cover most requirements. Plastic end fittings are included.

All dimensions are in mm

$L_{max}$  = Length +/- 2

B = Stroke

F1 = Spring force in Newtons

Extension speed: ~ 0.1 m/s

Colours: Black products are supplied with black end fittings 8962 and 8963. Grey products have a chrome piston rod and are supplied with grey end fittings 1116 and 1117. See page 188.

1 kp = 9.80665 Newtons, 1 Newton = 0.10197 kp

| $L_{max}$ | L   | B  | F1  | Colour | Cat. no. |
|-----------|-----|----|-----|--------|----------|
| 259       | 222 | 90 | 100 | Black  | 0883     |
| 259       | 222 | 90 | 150 | Black  | 0884     |
| 259       | 222 | 90 | 100 | Grey   | 0885     |
| 259       | 222 | 90 | 150 | Grey   | 0886     |

## Fitting instructions

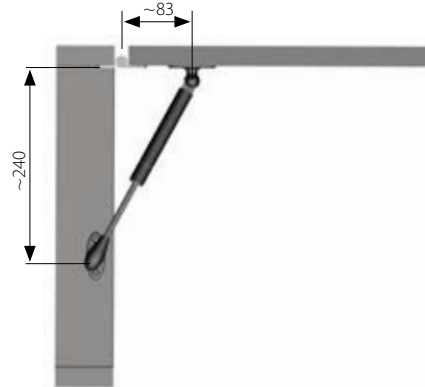

## Choice of force and number of gas springs

